

# Application Acceleration Basics

Robin Layland



Robin@layland.com

## Why care about Application Acceleration?

- Remote users complain about response time
- Files and attachments take forever
- Data Center consolidation
- Backups are slow
- Applications moving to HTTP
- Need to get more out of existing bandwidth
  - Save money / reduce cost



# How: Acceleration Techniques

Compression	Standards based	←
	Advanced	
Caching	Data Center	←
	Remote	
	Browser	
TCP	Flow Control	
	Connection Pooling	
	Error Correction	
QoS & Application Shaping		
SSL Off-load		
Application Specific	HTTP	←
	Microsoft's CIFS	
	VoIP	
	Others	



# How: Advance Compression

Dictionary, large pattern recognition....

## First Packet

Example of using patterns to make a message shorter → Send the entire sentence plus information on the table

Build table →

1	Example of
2	using patterns
3	to make a
4	message shorter

## Second Packet

Using patterns makes the message shorter → (Reference to entry 2) makes the (reference to entry 4)

Update table →

1	Example of
2	using patterns
3	to make a
4	message shorter
5	makes the



# How: Caching

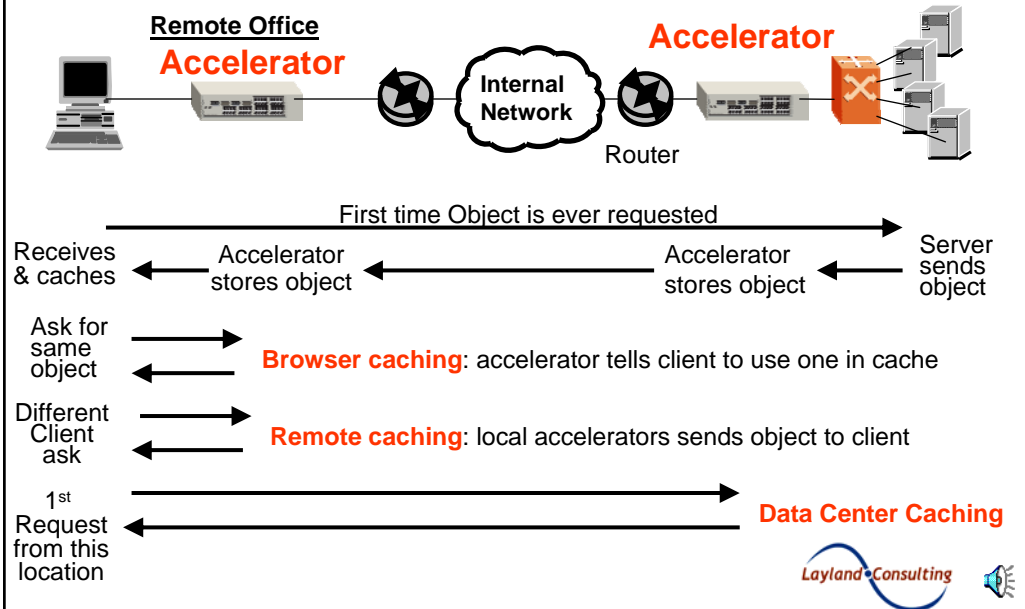

# How: CIFS Protocol Problem

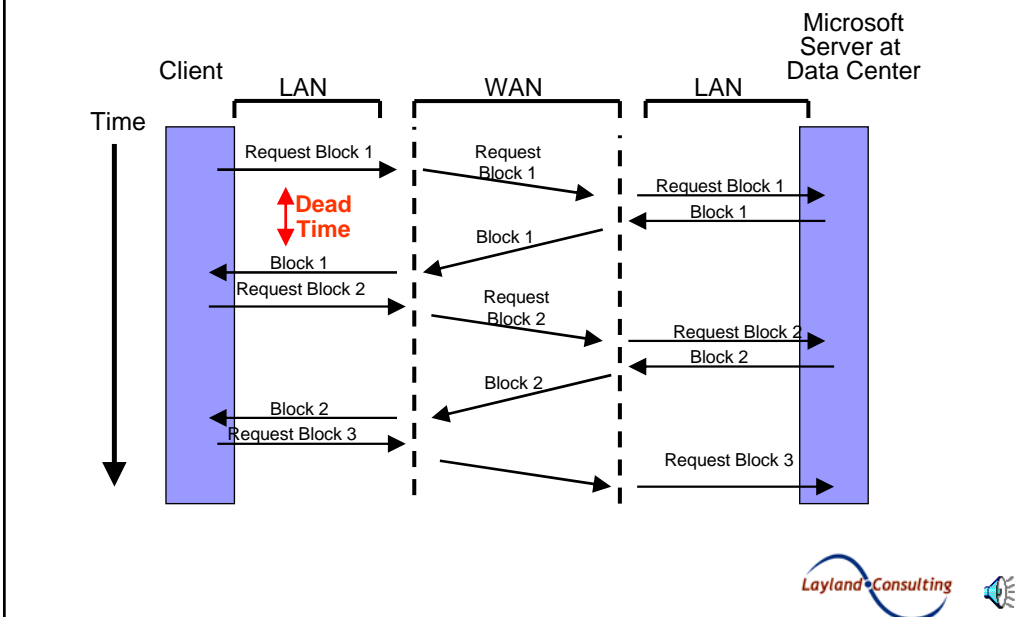

# How: Solving CIFS Problem

## WAFS – Wide Area File Server

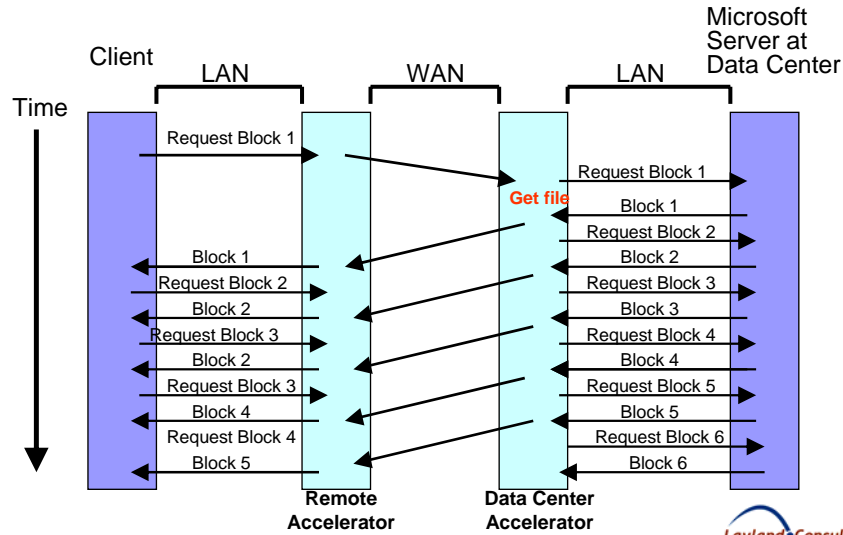

# How: Acceleration Techniques

<b>Compression</b>	Standards based
	Advanced
<b>Caching</b>	Data Center
	Remote
	Browser
<b>TCP</b>	Flow Control
	Connection Pooling
	Error Correction
<b>QoS &amp; Application Shaping</b>	
<b>SSL Off-load</b>	
<b>Application Specific</b>	HTTP
	WAFS / CIFS
	VoIP
	Others



# Acceleration: Where?

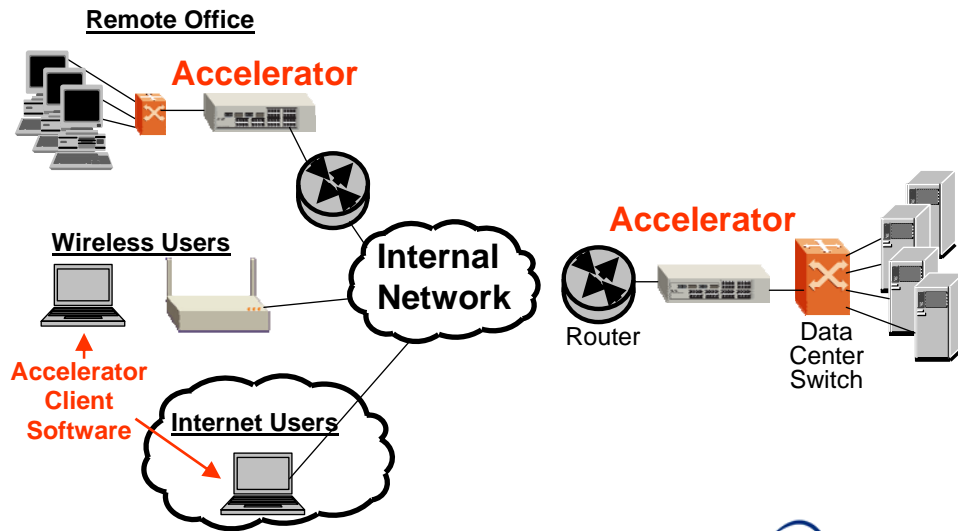

## Key Issues

- Good news: Real world feedback is acceleration works
- Differences between implementation
  - Application specific
  - Implementations can vary widely, example if WAFS
- Importance of application monitoring and understanding what is using the network
- Look closely at what special techniques they have
  - Are they working on techniques that help your major applications
- Overall packaging

## Application Acceleration Presentation

- Asked each vendor to give a presentation on a key issue, techniques or technology they use to accelerate applications
- All the vendors do more than just what they present
- The text part of the Challenge has more details on the vendor's offering



## More Information

- To learn more contact each of the vendors
- More information on vendor's web site
- Addition Resources available on topic at Webtorials and Layland.com

